

Technical data

S.CF 24 G – 40' LX

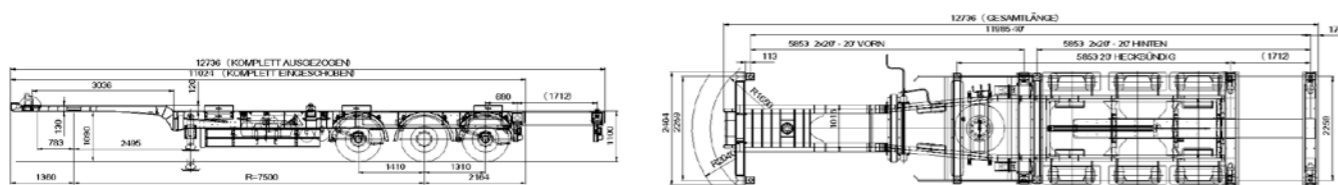

Permissible / technical axle load	24,000 kg	27,000 kg
Permissible / technical trailer load	11,000 kg	12,000 kg
Permissible / technical total weight	35,000 kg	39,000 kg
Unladen weight basic configuration		4,980 kg
Fifth-wheel height, unladen		1,100 mm
Fifth-wheel height, laden		1,075 mm
Low bed loading height, unladen		1,100 mm
Low bed loading height, laden		1,075 mm
Crank height		120 mm
Body height at front frame neck incl. pick-up plate (neck height)		130 mm
Front beam		1,650 mm
Wheelbase		7,500 mm
Front axle spacing		1,410 mm
Rear axle spacing		1,310 mm
20' flush with rear		Standard
2 x 20'		Standard
40' with tunnel		Standard
40' without tunnel		Option

We reserve the right to make technical changes.

One-Stop Solution

Premium Services from Schmitz Cargobull



SCHMITZ
CARGOBULL

The Trailer Company.



Container Chassis S.CF 40' LX

The Perfect Platform for Efficient Container Transport

Benefits at a glance:

- Tailored: prepared for 20' containers, 2x20' and 40' tunnel containers
- Expandable: optional locking mechanism for 40' containers without tunnel
- User-friendly: pneumatic rear extension with mechanical lock
- Practical: container positioned flush with rear, no problematic protrusions

S.CF-40'-FLY-DEGB-10219-5120 We reserve the right to make changes. Some illustrations show special equipment.

Container Chassis S.CF 40' LX

The Practical Optimised Alternatives for 20' and 40' Containers

The S.CF 40' LX offers you the perfect platform when the efficient transport of 20' and 40' containers positioned flush with the rear of the trailer are the top priority.

It carries 20' container positioned flush with the rear of the trailer as well as 2 x 20' containers and 40' tunnel containers.

The locking mechanism concept: Standard TWIST LOCKS on the 2nd and 4th container beams, folding locks on the rigid front beam, KLAPP LOCK for securing the front container when transporting 2 x 20' containers and STEP LOCK® as a height adjustment option for 40' containers without a tunnel. The pneumatic central tube rear extension is a user-friendly and time-saving solution and does not require special adjustment for 40' containers without a tunnel.

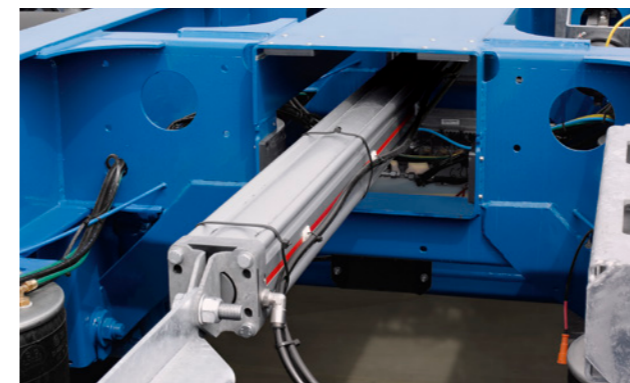
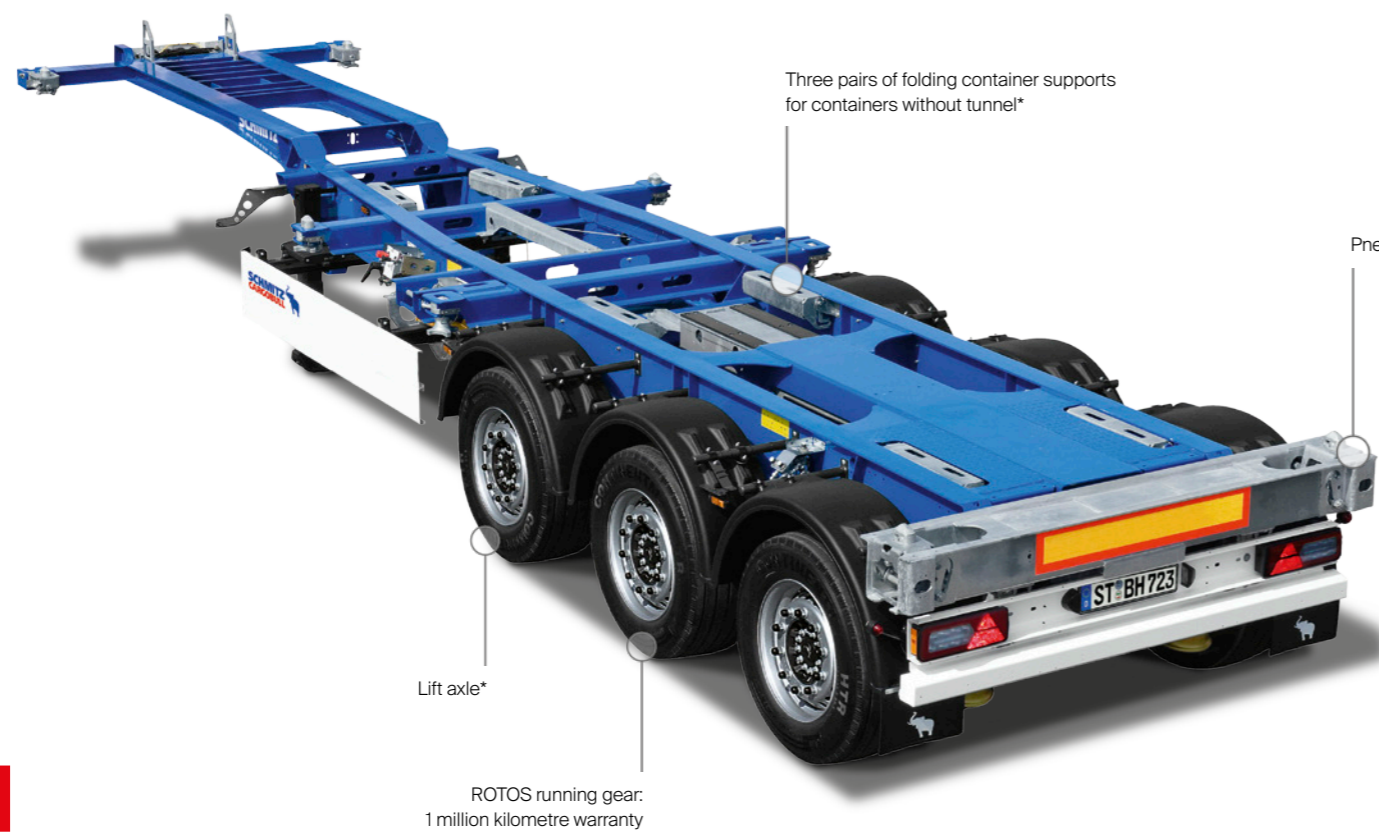

Long service life: Schmitz Cargobull container chassis are constructed using high-strength steel profiles and systematically protected against corrosion.



The **rear extension** pneumatically extends to the selected container position.

Container layout

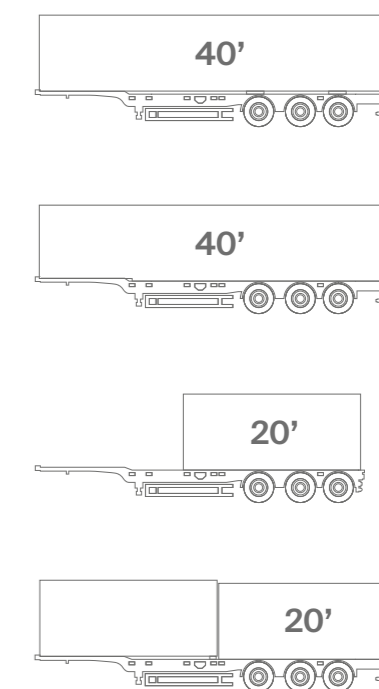

Two **STEP LOCKS**** on the rear extension allow you to adjust your semi-trailer container chassis in a matter of moments.



With 2x20' loads the two **KLAPP LOCKS** serve to lock the rear end of the front container.



Folding locks on the rigid front beam for TWIST LOCK or **PIN locks** for tunnel containers.



The lift **axle*** as a starting aid extends the wheelbase and, thus, increases the pressure on the drive axle.

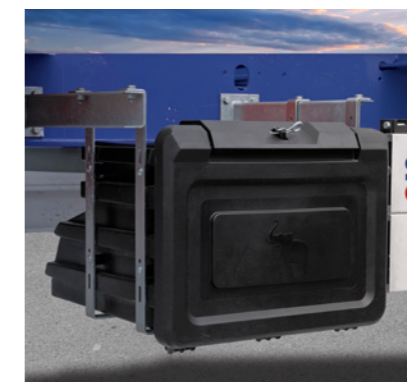

The sturdy **toolbox*** safely and cleanly stores all necessary equipment.



The container trailer chassis can be equipped with **ferry lashings*** for use with ferry transport.

Illustrations may include optional equipment. * Optional.